

Communications for Model Railroads

Seth Neumann

seth@modelrailroadcontrolsystems.com

Agenda

- A little History
- Design Considerations
- Modeling From the Prototype
- What Era are You Modeling?
- How to Put it Together
- Hints & Resources

Caveat: “Generally in the West”

Design Considerations

Era/Technology

**Jobs you want
to model**

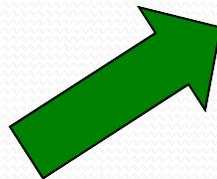
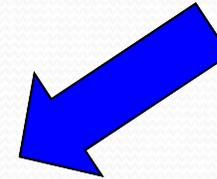
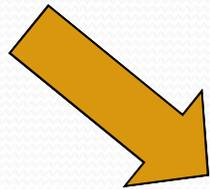

Prototype

**Space in your
Railroad room**

Communications for Operations

- Different eras had different dispatching models based on available communications: the history of dispatching is the history of communications technology
 - TT&TO: Telegraph/Telephone:
 - CTC: Telephone/Radio
 - DTC, TWC: Radio



Communications Time Line

- 1845: Telegraph invented
- 1850: Telegraph used by Railroads
- 1851: Charles Minot uses Telegraph to send 1st Train Order on Erie RR
- 1869: Telephone invented
- 1920s: Telephone in widespread use for TT&TO dispatching
- 1925: CTC appears, phone booths provided at ends of controlled sidings
- 1940s: Telegraph largely supplanted by Telephone
- WWII: CTC becomes common on western mainlines
- 1960s: Radio becomes widespread, Train Orders copied over radio
- 1980s: Radio becomes ubiquitous, TWC/DTC appear in 1985

Your Prototype

- What did your prototype do in your era?
 - Single track with passing sidings?
 - Double track, rule 251?
 - Style of dispatching:
 - TT&TO
 - CTC/TCS
 - Radio
- TT&TO requires Train Order Offices, preferably with Train Order signals
- CTC requires phones at each controlled signal



Modeling Jobs on The Railroad

Operations is modeling the work of the railroad. Like everything else in model railroading, jobs are selectively compressed: we like to do the fun parts but not the boring, tedious and dangerous parts. In the transition era there were 10 clerks for every one person in train service. We could not fit all of the clerks for one good op session in this room!

Jobs to Model:

- Dispatcher
- Train Crews
- Operators (for TT&TO)
 - One for whole layout?
 - One at each station?
 - Where can you put them?
 - On many model RRs, the Conductor magically morphs into the Operator at each TO office to OS

What are you trying to model?

- Communications *among* DS and Operators? (TT&TO)
 - Open speakers – a wireless intercom is a quick and dirty choice IF the DS and Agent/Operators are in quiet places, isolated from the railroad. You could also build something using phone hardware OR
 - Telegraph (RR Morse or International Morse)
 - Use phones with amplified speaker across the line, provide Push to Talk and/or noise canceling microphone to control feedback
 - Remember real crews *rarely* OSd themselves, so having the crew OS is *generally* a “model railroad thought”
- Communications *between* DS and crews (CTC)
 - Idea is to keep crews “isolated” (no radio chatter)
 - Need to go to a “station” or phone booth to talk
 - “Call Lamps” on relay shacks set by DS on the CTC machine

Understand your operational requirements!

Your Layout: Givens and 'Druthers

- How much space do you have?
 - Do you have room for sound-isolated Operators' stations?
 - Where to place telephones (by the station –TT&TO, at control points – CTC)
 - Aisle width
 - Places to write
- How much chatter do you want in the layout room?
- Arrangements for displaying train order signals, (Semaphores, Searchlights, hooks below layout)
- Do you want prototypical phone instruments or would more comfortable and durable (and potentially less expensive) modern (but anachronistic) equivalents be better?

Hill Board - Eugene

Part of Radio System

Phone Speaker

Shure SM55
"Elvis" Mic



Valley Board (Brooklyn Sub)-Eugene



2554 Set

Lunch

Computer Terminal

Shure SM55
"Elvis" Mic

A young and well
caffeinated "Breezy" Gust

WP Sacramento CTC (TCS) Board

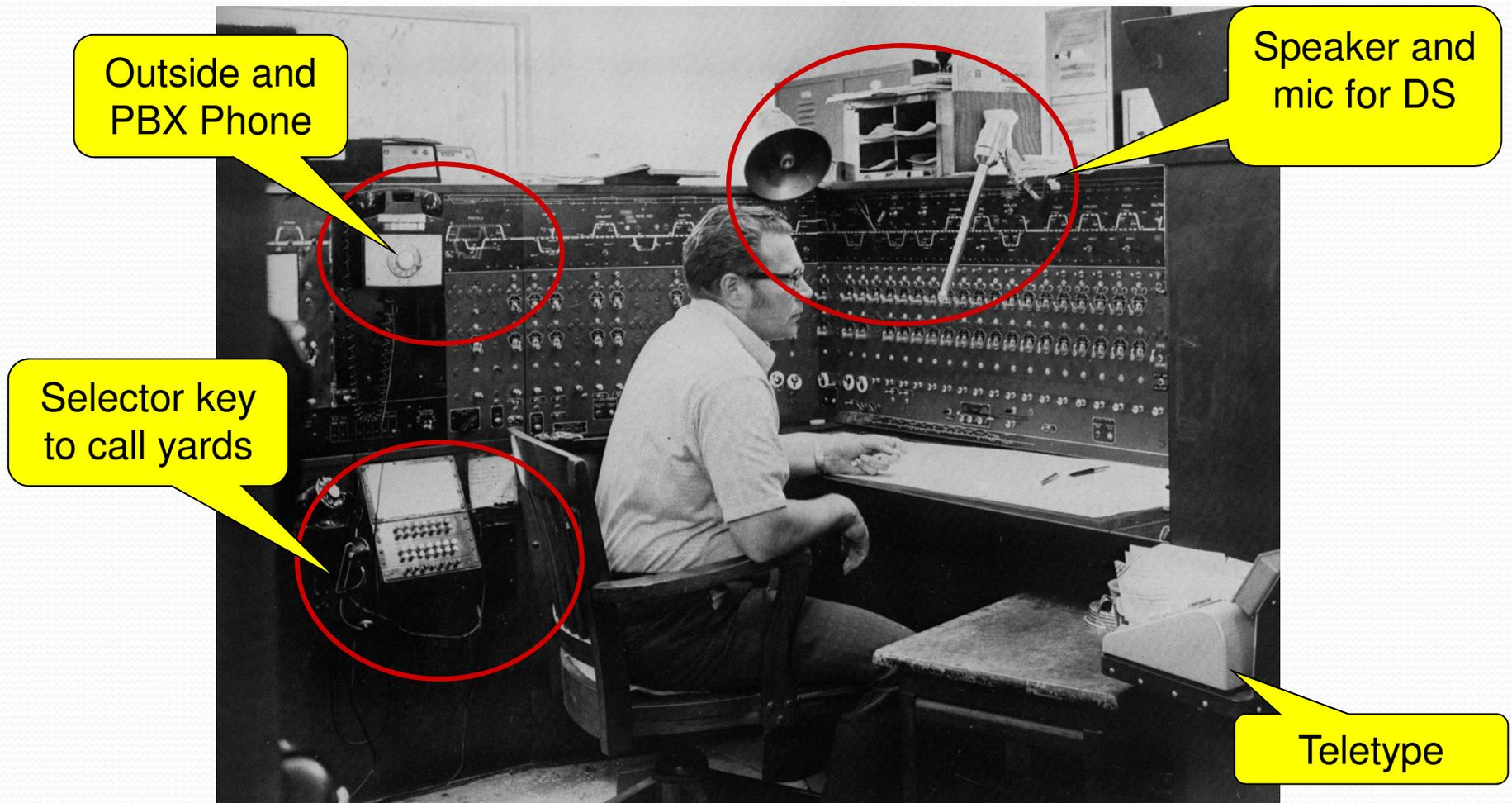

How it Worked under CTC

- Employee Call lights driven by field equipment on code line
- Phones were “local battery” (like Magneto (“crank”) phones) with push-to-talk handsets and interlocks with door latches in phone booths (to save battery)
- DS had a speaker (always on except when talking), a microphone and a footswitch (stomp-to-talk)

How did it work (CTC)? - 1

- DS Calls a train:
 - DS sets Signal to “stop” at OS Section (Control Point) ahead of train
 - DS sets “Employee Call” lamp lever for that station
 - DS presses code button
 - lamp on “phone booth” lights & latches
 - Crew picks up phone (having seen lighted phone booth on arrival at station)
 - Crew announces “Dora”
 - DS acknowledges, gives instructions
 - DS clears Employee Call lamp

How did it work (CTC)? - 2

- Train Crew calls from Siding:
 - Conductor goes off hook at phone and announces (“Edna”)
 - DS hears speaker or DS phone buzzes
 - Or DS goes off hook – buzzer stops (speaker muted, if present)
 - DS answers
 - Conversation
 - Everyone goes back on hook

How did it work? (TT&TO) - 1

- OS from Station:
 - Station Operator (Conductor) goes off hook and announces station “OS Franny”
 - DS hears through speaker or headset
 - DS answers “go ahead Franny”
 - OS transmitted: “X1234 West by at 245 PM”
 - Everyone goes back on hook
 - Your prototype may have had minor variations, embrace them!

How Did it Work (TT&TO) -2

- DS Calls an unmanned station:
 - DS presses button corresponding to station(s)
 - Since the DS would not call an unmanned station this is a “model railroad thought” but if you have train order boards, the DS would drop the board and wait for the crew to arrive and morph into the Operator.
 - If not, Station buzzes, (optionally) lamp on “phone booth” lights & locks
 - Station answers (when crew sees lighted phone booth) – light extinguishes
 - TO read & copied (“EXTRA 1234 WEST MEET NO 3, ENG 9876 AT DORA”)
 - Everyone goes back on hook

How Did it work? (TT&TO) - 3

DS calls Operator (manned station)

- Operator is listening on speaker or headset (or bell or buzzer sounds)
- DS Calls Helen Station with key (button or lever)
- Station responds “Helen”
- DS responds with “19 West Copy 2”
- Op answers “SD” and “Ready to copy”
- TO read and read back, OK’d
- Everyone goes on hook

How should it work? - 4

DS calls Yard Master (manned station)

- Station buzzes and optionally latches with lamp*
- Operator answers with station name
- DS responds with whatever he needs (Status of train in yard, “soup”, etc)
- Information exchanged
- Everyone goes on hook

Simple Phone System

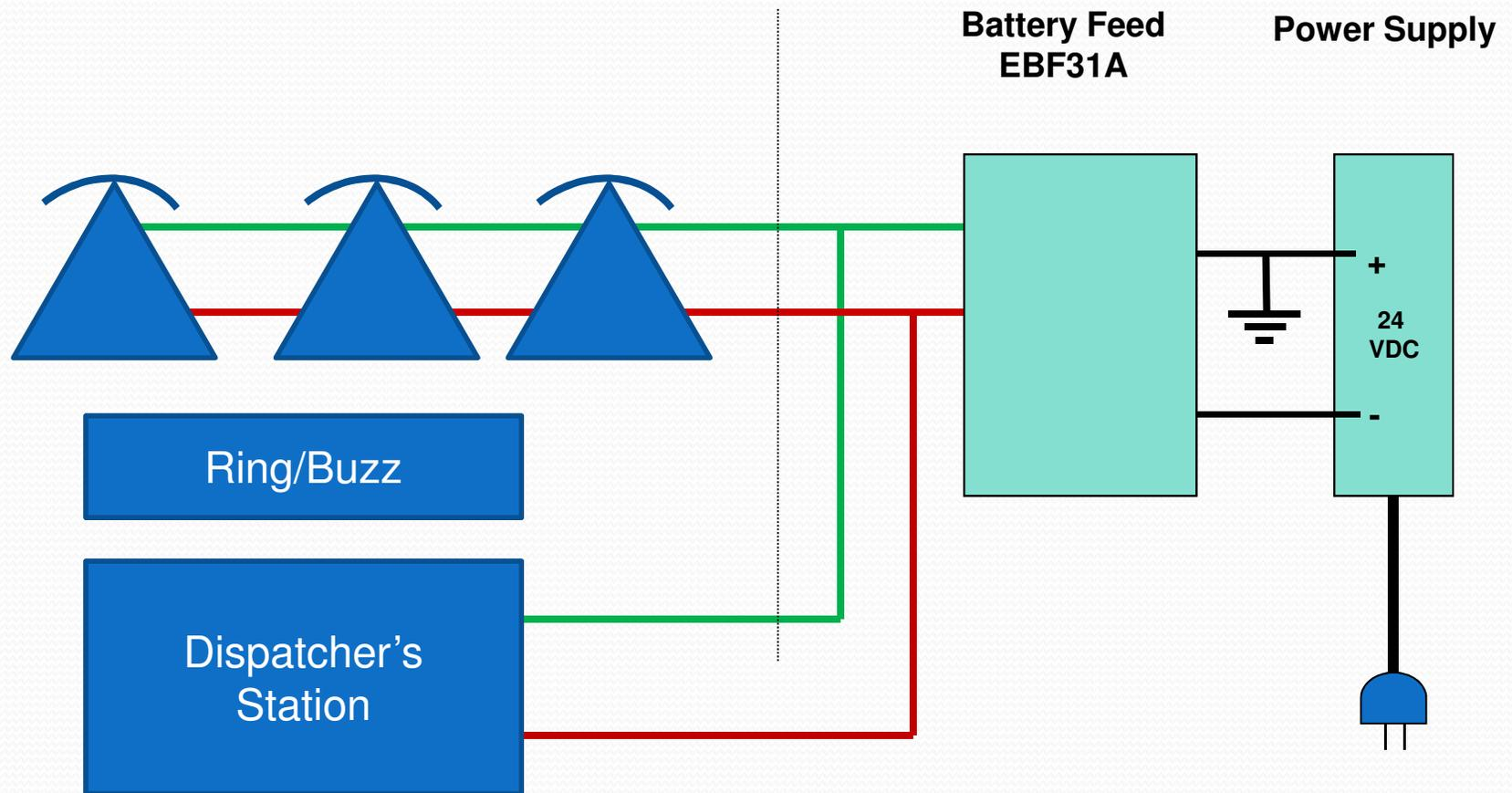

How to Model - Planning

- Determine where the DS will work. Is it a separate room?
- Determine where the phones will be. Do you have room for a phone at each end of each controlled siding?
- Find a clean, well lighted place for the common equipment. Be sure there is room to work, you'll be spending some time here!

Stations

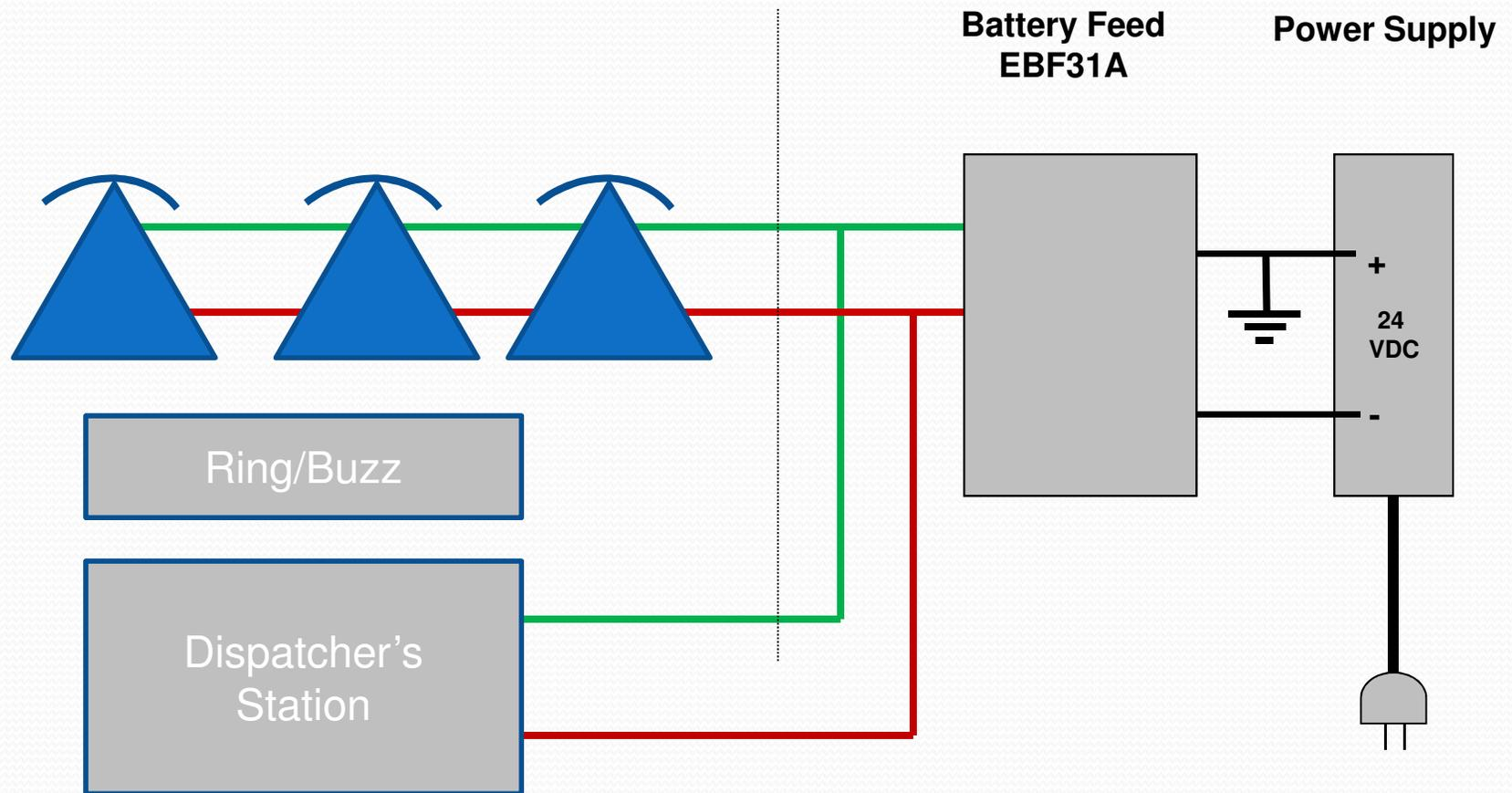

How to Model it - Station

- There are many ways to do stations
- Here's what Tommy Holt did: (note the Call Lamp on the phone)
- I recommend stations have Push To Talk (PTT) switches and/or noise canceling mics
- Enforce communications discipline: use standard forms, minimize chatter.



Stations



211 w/ F handset

554/2554 without Case and dial, Installed thru fascia



2554



Custom

554



Shoot with painted fascia

Possible Station Solutions

Custom w/ Push to Talk Handset	Most flexible	\$85
Vintage	swap meets, web vendors	\$50-250
554/2554 Wall Set	Wherever you can find, garage sales	< \$50
Big Box Cheapie on modular plate	Buy a few spares, anachronistic. Some control circuits won't work	\$ 15

“Space Saver”

- W.E 211 type “space saver”
- Doesn’t take much space in aisle
- Needs external speech network and ringer/buzzer*
- Appropriate for 20’s thru 80’s
- Originally had E or F type handset – consider replacing with G type handset (correct for 50s through 80s)
- MRCS sells for ~\$195 depending on options

Re-shoot with light back ground



302/354 Set



- 302 type desk set
- Has internal speech network
- Appropriate for 30s through early 50s
- Equipped with F type handset
- 354 wall set available (after 1947), Repros by Crosley \$60
- Phoneco (Original) \geq \$200

500/554 Set

- 500 type desk set
- Designed by Henry Dreyfus of NYC Hudson fame
- Improved internal speech network
- Appropriate for 50s through 80s
- Equipped with G type handset
- Hook switch has useful extra contacts
- Phoneco \geq \$99, but often available ~\$25 at garage sales and swap meets -- beware of late model versions with electronic guts
- MRCS has used sets for \$40 subject to availability



Roll your own

- Electrically a 500 set
 - G type handset
 - 425 or equiv type network
 - Cradle and hook switch
- Usually fascia mounted
- MRCS sells parts – new ones can be assembled for \$85 and up, we have used parts from time to time



Yosemite Valley RR - Jack Burgess

Always use a Speech Network

- The little square terminal block in the phone
- Controls Side Tone (your own voice in your ear)
- Puts more of the speech energy out on the line
- Protects against clicks and pops on the line
- Limits current into the phone so it doesn't hog all the current in a party line environment. 300 series sets have a primitive version which is usually OK for our purposes (generally no need to hack up a vintage set)

Bring a network or two to show

Dispatcher

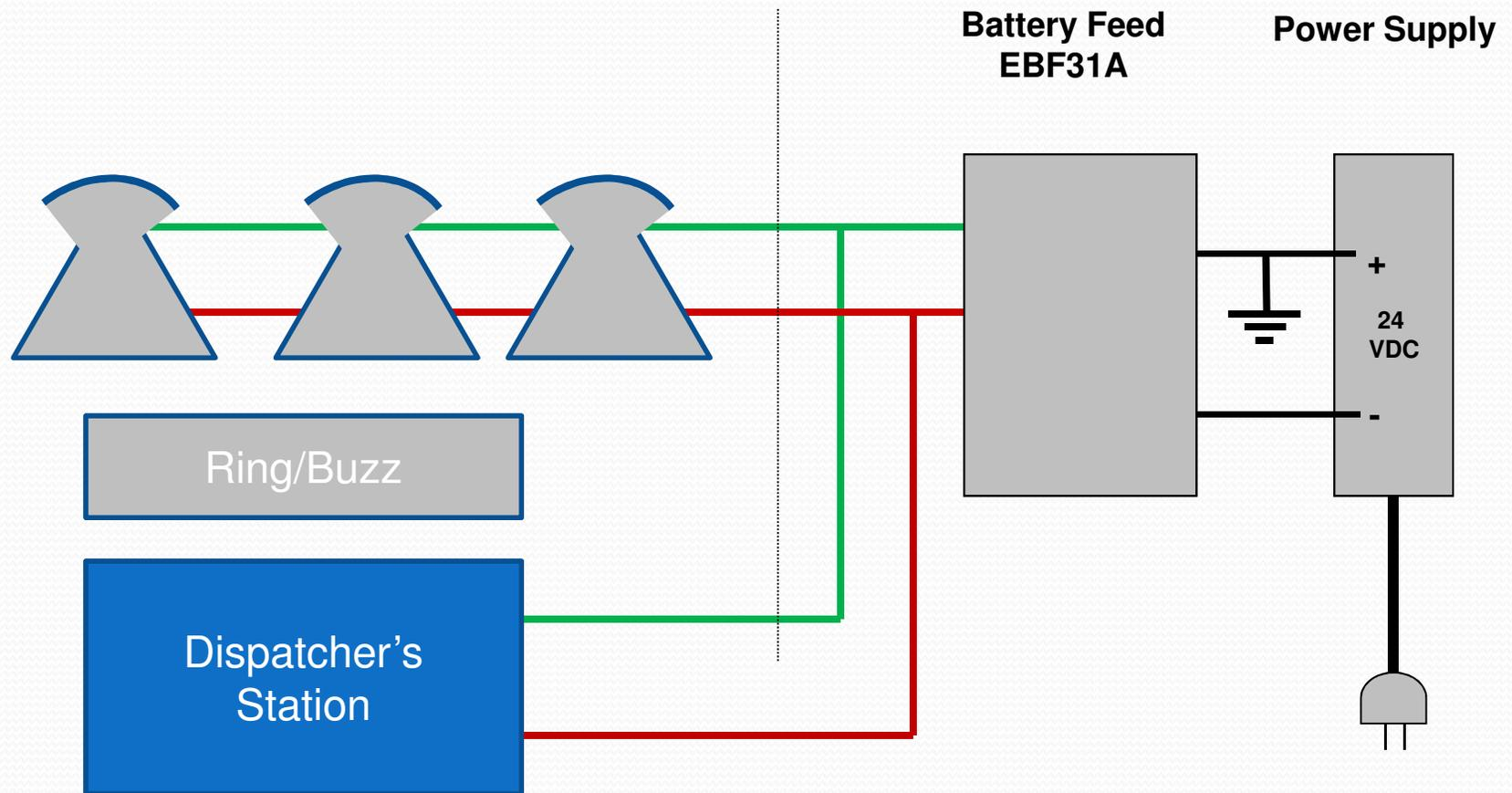

How to Model it – Dispatcher/Operator

- If there is a separate, sound-isolated room for the CTC machine, I recommend using the microphone /speaker/footswitch arrangement. You may want to match photos of your prototype's dispatcher's office, if available.
- If the DS or OP is out in the layout room, it's best to use a noise cancelling headset with a footswitch
 - Call Center type headsets are available from many vendors starting at about \$125 and can work with virtually any phone. Footswitch can be added.
 - MRCS sells a single board for a dispatcher's set that supports either a dynamic mic/speaker/stomper or a computer headset, this allows use of an inexpensive (\$10-40) computer headset.
- In any case the DS should be able to work with both hands free.

Dispatcher Phones



Possible Dispatcher Solutions

Scissor Mount Candlestick with Headset (listen on headset)	Antique telephone suppliers	\$250-\$500 depending on condition
“PA” type microphone with speaker	Commercial sources, see example later and demo	\$25-250
Modern Phone with headset (listen on headset)	HelloDirect, etc	< \$250
Modern Phone with buzzer, relay control	Whatever you can find, garage sales	\$ 50
Noise Cancelling Headset	Call Center Style or MRCS board with computer headset	\$110-150

Almost Anything Goes!

Motorola Control Heads

Dot Matrix Printer Circa 1980

IBM 327X Terminal Circa 1980

554 Set

211 space saver

107C Loudspeaker

Scissor Mount Candlestick circa 1915

Ash Tray full of Butts!

Dorothy Aull at XN Tower

Typewriter!

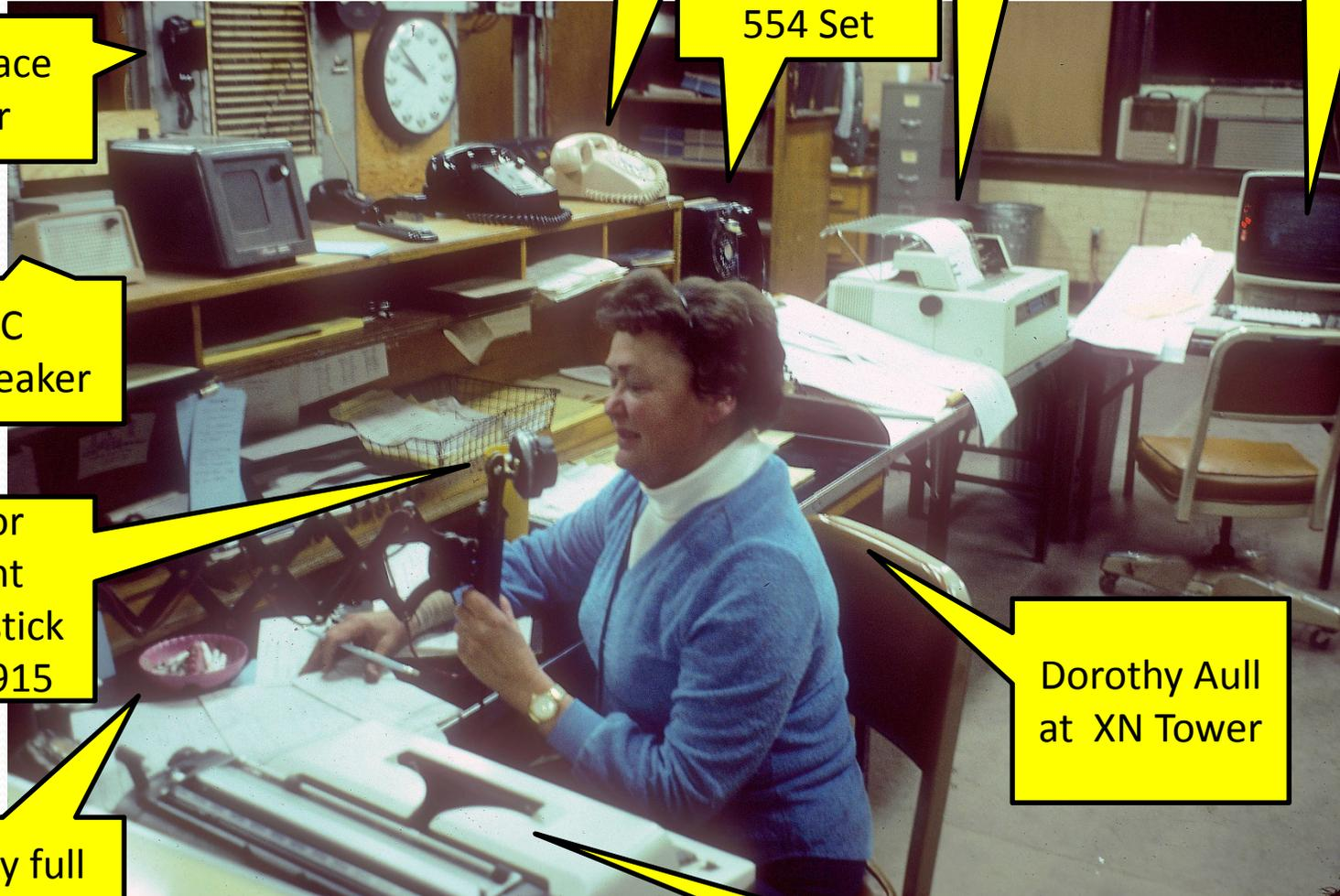

Mic/Speaker Arrangement



You can use a standard Dynamic Mic, as Ed Loizeaux did in the example to the right. I recommend amplified computer speakers or vintage telco type amplified speakers, match to your era or photo.



Dispatcher Bill of Materials

Quan	Description	Price	Vendor
1	Microphone	\$ 20	
1	MRCS DS Board	\$ 85	MRCS
1	Mic Stand	\$ 15	Sweetwater, B&H
1	Amplified Speaker	\$ 15 and up	Amazon, Fry's
1	24V Regulated Wall Wart	\$ 20	Jameco
1	Footswitch	\$ 20	MRCS
	Total	\$ 175 +	

Quan	Description	Price	Vendor
1	Noise Cancelling Computer Mic	\$ 10-40	Amazon
1	MRCS DS Board	\$ 85	MRCS
1	24V Regulated Wall Wart	\$ 20	Jameco
1	Footswitch	\$ 20	MRCS
	Total	\$ 135 +	

Our (MRCS) Dispatcher Board



- Separate adjustments for outbound mic volume, speaker volume and for the amount "break-in" traffic is muted when the DS is talking.
- Operates from filtered 24V, includes a 2.5mm barrel jack for a 24V wall wart
- Does not load the line, so the "off hook" contacts from an associated EBF31A or 31A KTU will indicate when stations are off hook
- Mic in and line level out to speaker/headset output on 3.5mm jacks screw terminal connection for (user supplied) footswitch
- RJ11 Modular and screw connections for telephone line
- Compatible with 24V and 48V phone systems
- Output phase switch to minimize feedback, especially when adjusting "break-in" level
- Multiple boards may be used on one system
- Transmission direction is controlled by the footswitch: "Stomp to Talk" operation

Dispatcher Foot Switch

- Use a period phone style switch
- Use the switch from your resistance soldering rig with an AC relay
- Use an inexpensive commercial footswitch (MRCS)
- Make one



8/18/2018

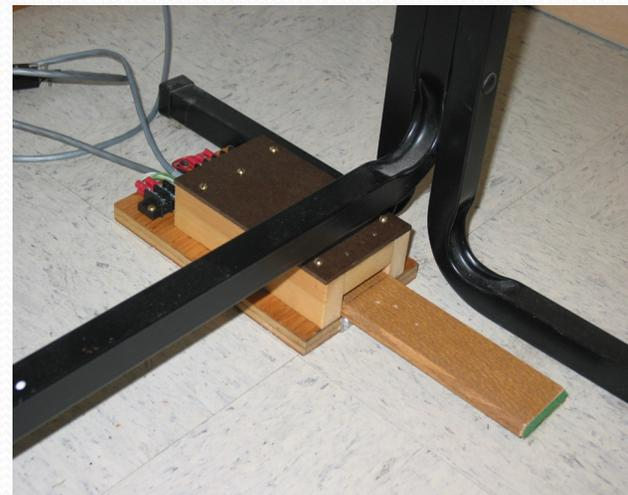

40

Powered Speakers



WEC0 100F



WEC0 106B

- Vintage Telco style 100F, 106, or 107 speakers, or use powered computer speakers (be sure to use a blocking capacitor) or a small amplifier and any speaker you have handy.
- MRCS boards (EBF, DS/OP) provide a buffered output (no capacitor required).

Common Equipment

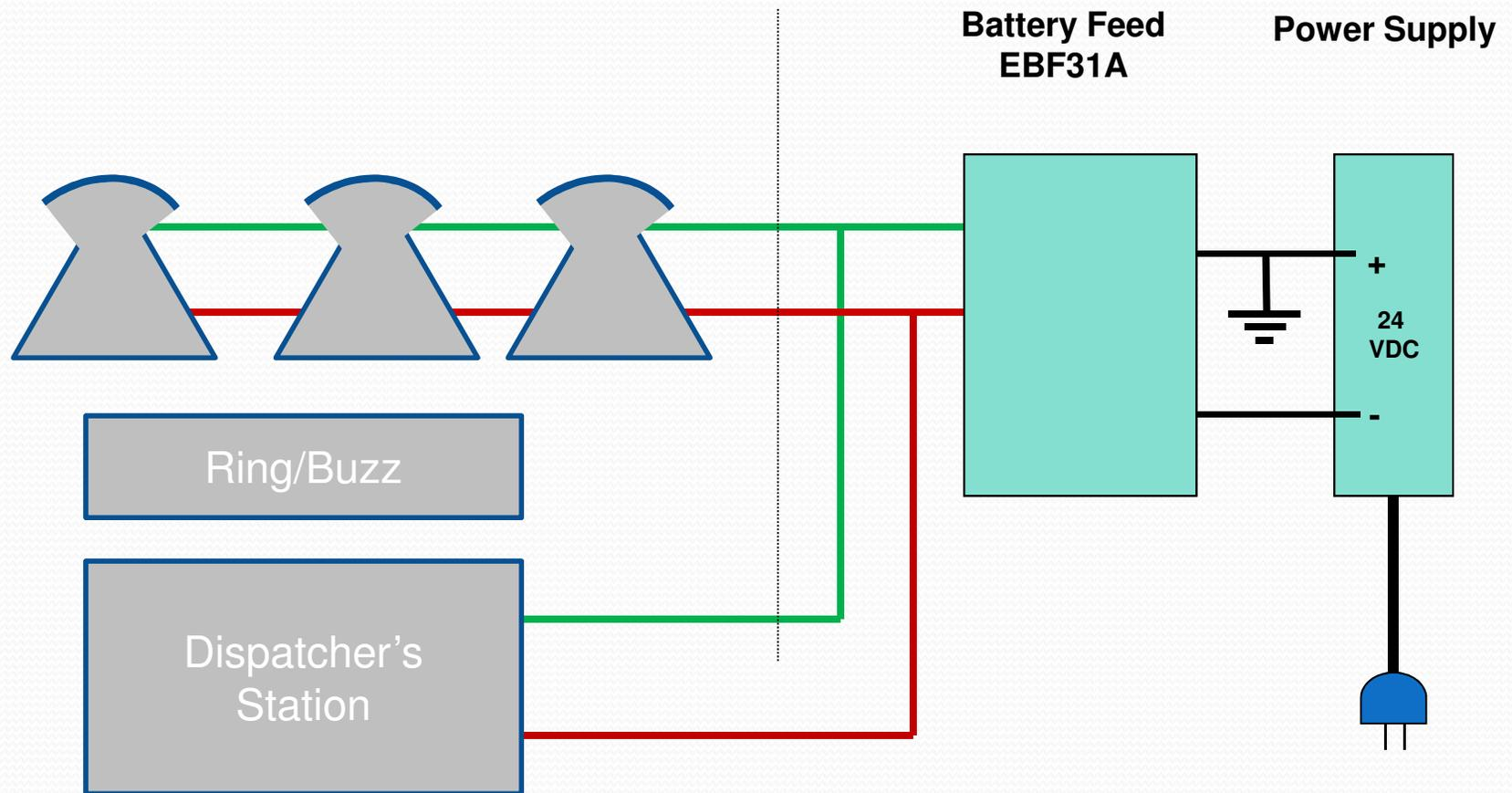

Common Equipment

- Power Supply – 24VDC regulated, a (250mA regulated) wall wart will work
- A “Battery Feed” source. These are balanced chokes found in classic telephone circuits or electronic equivalent (EBF31A)
- Connecting blocks, wire etc.
- Backboard

What is “Battery Feed?”

- Power for the phones
- DC v. AC
- What is “impedance?” (Z)
 - Think of it as AC resistance
 - A component (usually a choke coil) can have low DC R but high AC Z!
 - These have become scarce over the years, perhaps as a result of this clinic. MRCS offers an electronic equivalent (EBF31A)

Battery feed alternatives

- Our EBF_{31A}
- Battery feed relay (24 or 48V)
- Audio Freq chokes
- Retard coil (2A, 31A, 401A KTUs,)
- Telco style Intercom
- Electronic Battery Feed Board
- PBX is not recommended

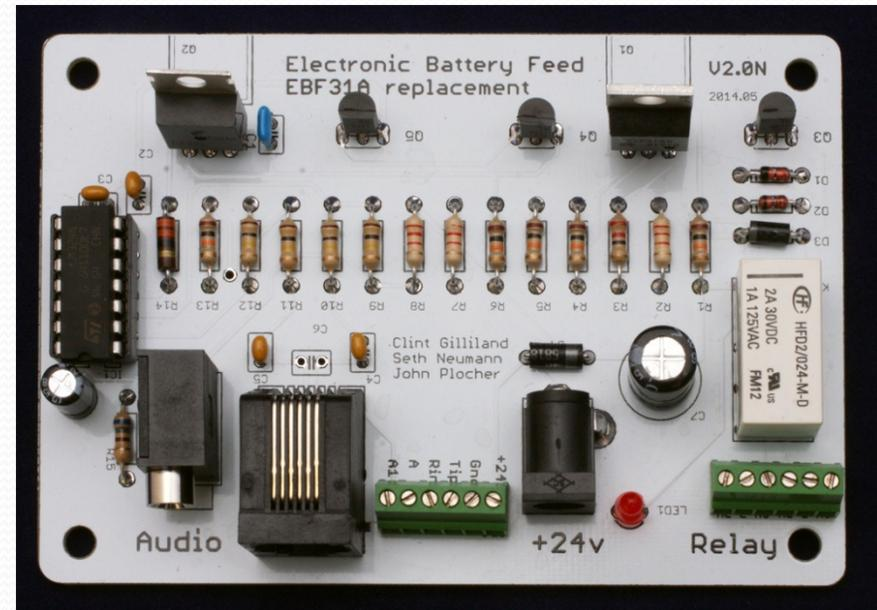

The goal is to have a relatively low DC Resistance (to power the phone) while keeping the impedance (AC resistance) at voice frequency as high as possible so we don't lose speech energy through the power supply (so we can hear).

Basic Phone System

Quan	Price	Description	Source	Ext'd	Note
6	\$ 25	554 or 2554 Wall Set	Yard Sale	\$ 150	*
1	\$ 50	Electronic Battery Feed	MRCS	\$ 50	
1	\$ 30	66 Block and Bracket	Big Box	\$ 30	**
1	\$ 110	Dispatcher set as above	Various	\$ 135	
1	\$ 100	Misc Hardware & Wire	Big Box	\$ 100	***
		Total		\$ 465	

Notes:

* Should be available locally or eBay, or use inexpensive wired sets from Walmart etc. If you can't find them, contact me

** This is the phone style connecting block. The electronics won't mind if you use barrier strips.

*** I recommend phone style D rings for wire routing, but big cable clamps will work fine

Our (MRCBS) System (today's demo)

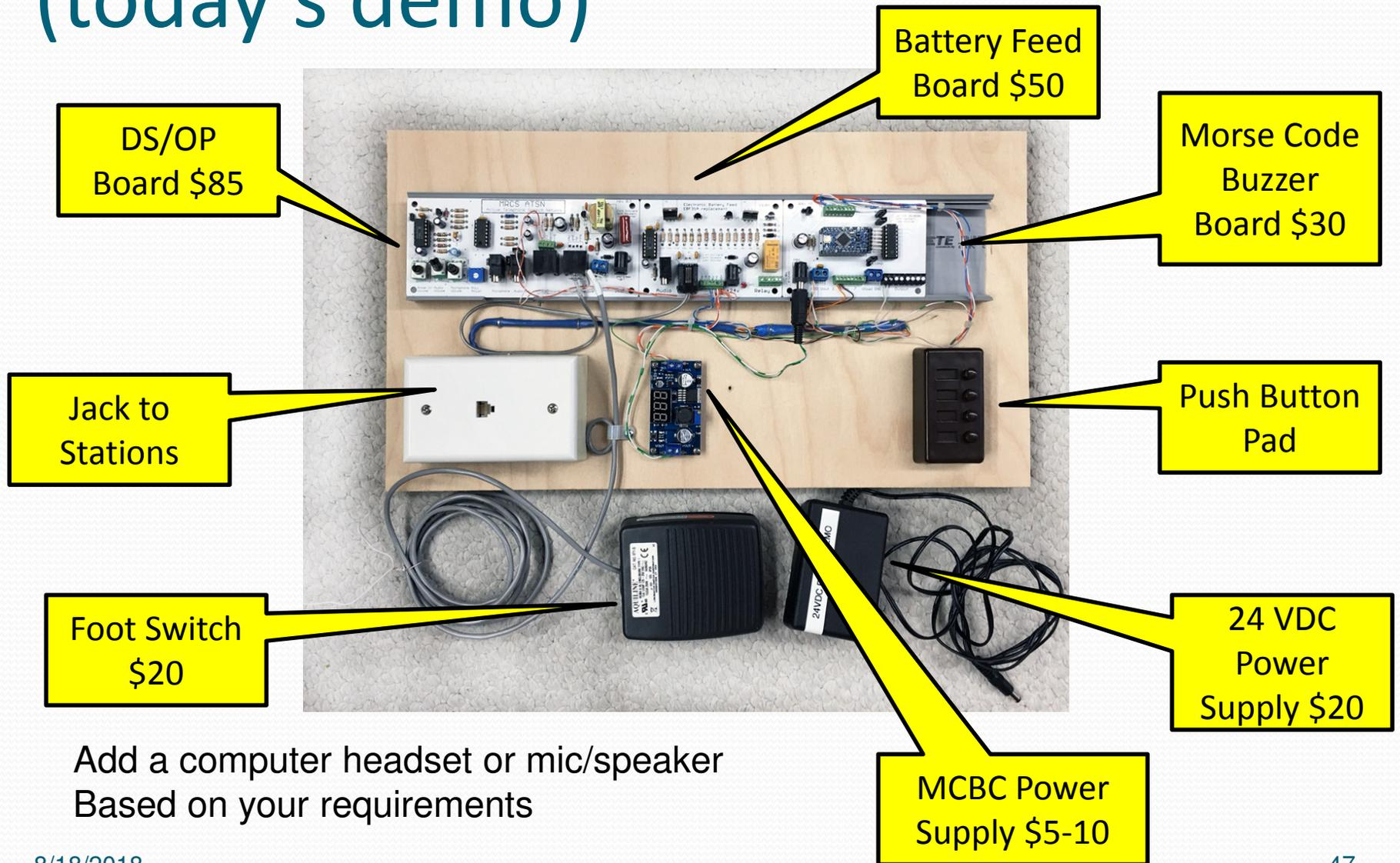

Ring/Buzz

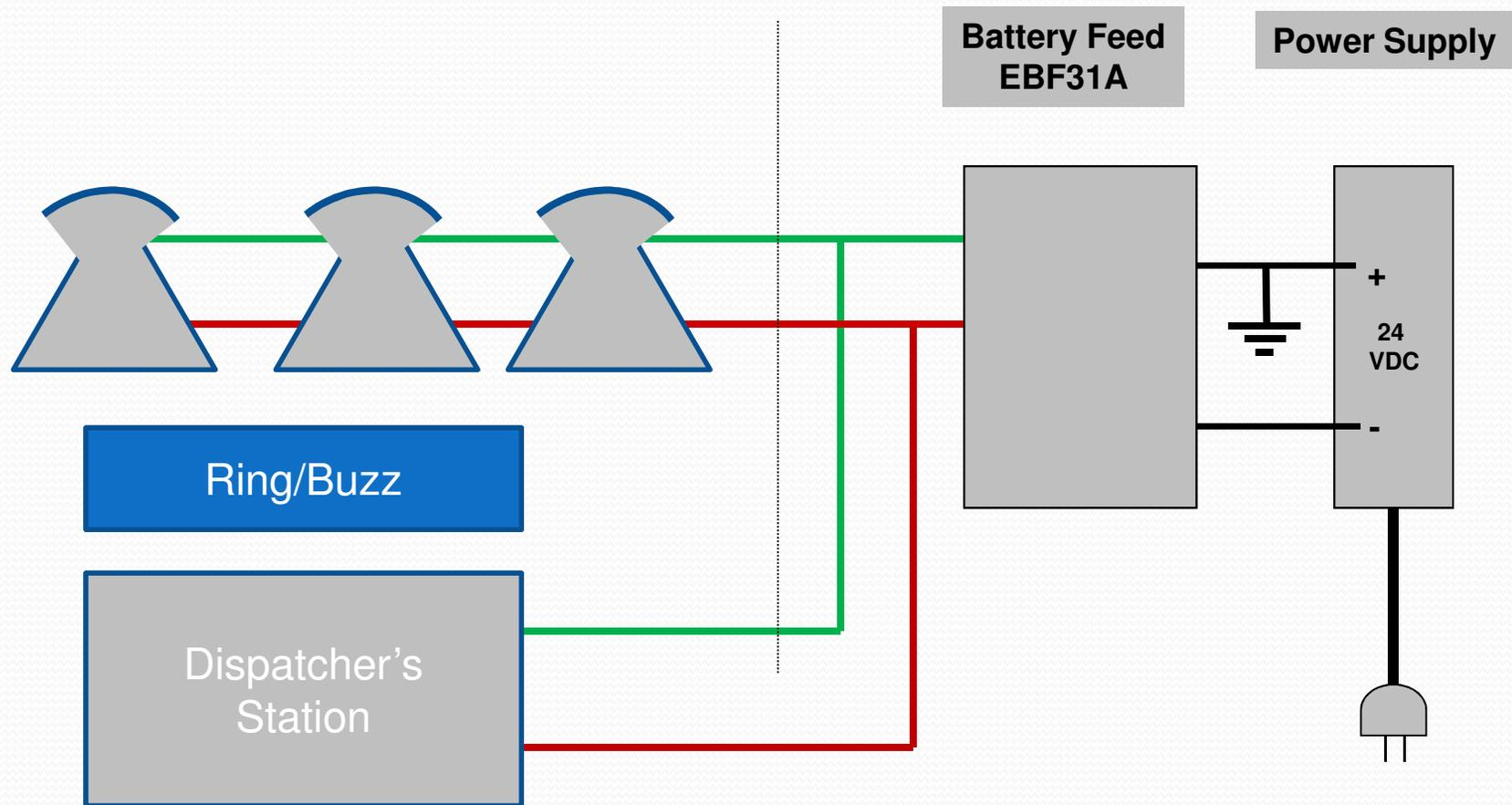

Signaling Stations

- TT&TO offices generally had Train Order boards (semaphore or lights) at other than originating and terminal stations (where all trains had to stop and get clearances)
- CTC generally had phone booths at control points with “Maintainer Call” or “Employee Call” lights
- On the model we often put the Yards and towers on the same circuit and need to contact manned stations. Buzzers, bells and lights are good options.
- We’ve made a board to tap out the station codes in Railroad Morse to give each manned a station a distinctive signal and keep the noise down.

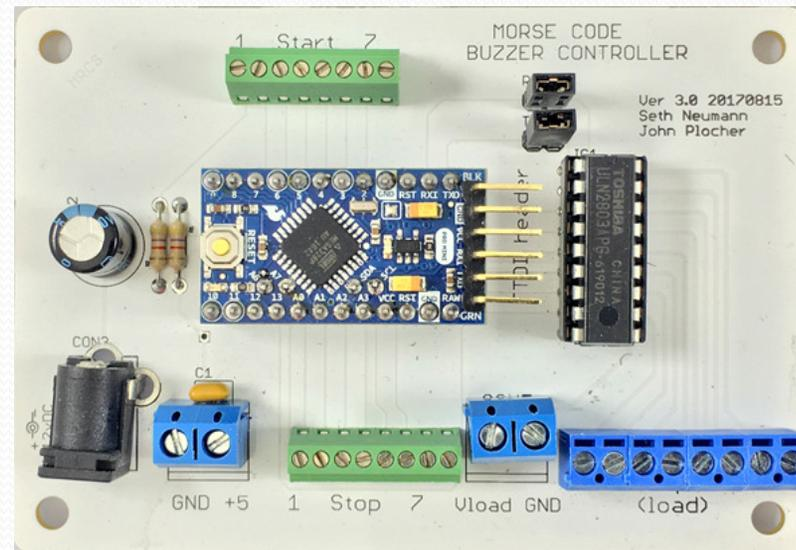

The Morse Code Buzzer Controller controls up to 7 stations plus an “ambience” output. It is driven by a small Arduino

Wiring hints

- Cat 5
- Color code:
 - Blue = talk
 - Orange = hook
 - Green = lights
 - Brown = buzz/ring
- Keep away from power, DCC, ballasts
- Add image

Noise/Adequate Volume

- Use high impedance battery feed if possible
- Busy indicator to warn of conversation in progress (user discipline)
- Push-to-talk (PTT) and/or noise canceling handsets
- DO NOT use amplified handsets except for the truly hearing impaired: they amplify the noise in the room, too!

Other

- Use Cat 5 (\$0.10- 0.15/ft), has 4 pair, or CAT 3 (if you can find it) for station wiring
- In any case, use twisted pair, helps reject noise (crosstalk from DCC)
- Use terminal strips or telephone style 66 blocks for connections, “Euro” connectors get loose on 24 Ga wire (YMMV)
- See our website for wiring diagrams

Bad Ideas:

- Wireless multi handset systems – cheap but take too much effort to make a call, no party line
- Non choked/balanced Battery Feed – low volume, poor side tone rejection, poor party line performance
- Series wiring – two stations only, poor sidetone rejection, any failure in wiring knocks the whole thing out

Resources

- Model Railroad Control Systems
<http://www.modelrailroadcontrolsystems.com/>
- Telephone Collectors International
<http://www.telephonecollectors.org/>
- Phoneco <http://www.phonecoinc.com>
- Graybar (major cities) www.graybar.com
- Telephone Components <http://www.telephonecomponents.com>
- Hello Direct <http://www.hellodirect.com/>
- Jameco (www.jameco.com)
- Mouser (www.mouser.com)

Print Resources

- My 3 Part Article in the OPSIG *Dispatchers' Office* April through October 2011. <http://www.opsig.org>
- Chapter 9 of the OPSIG “Compendium”



Special Thanks to:

- Mike Burgett
- Bruce Chubb
- Tommy Holt
- Steph Kerman
- Napa Club
- Kermit Paul
- Ludwell Sibley



Back up and old

Foot Switch Options



WECO Type 2A/ Grainger

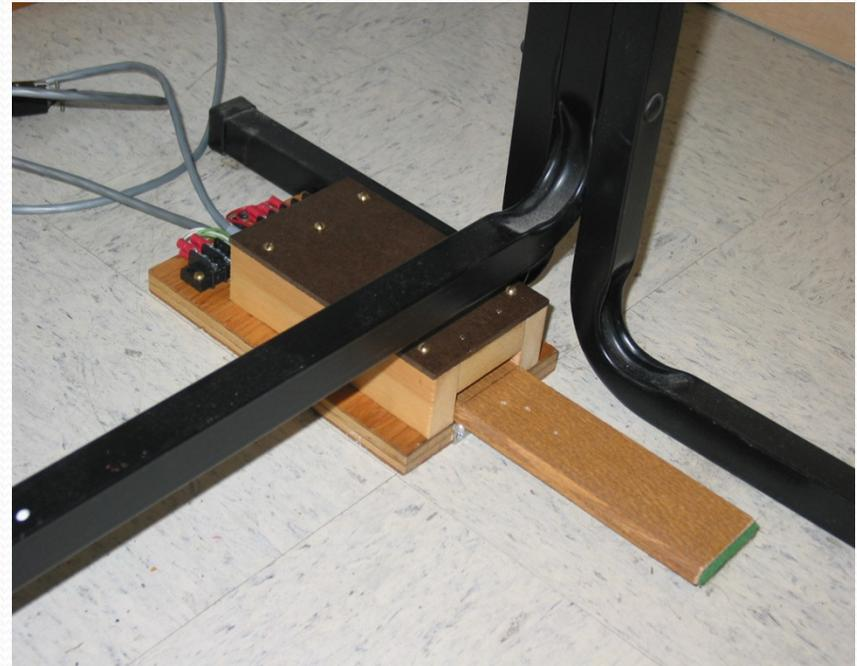

Dave Adams made this

Dispatcher Arrangement

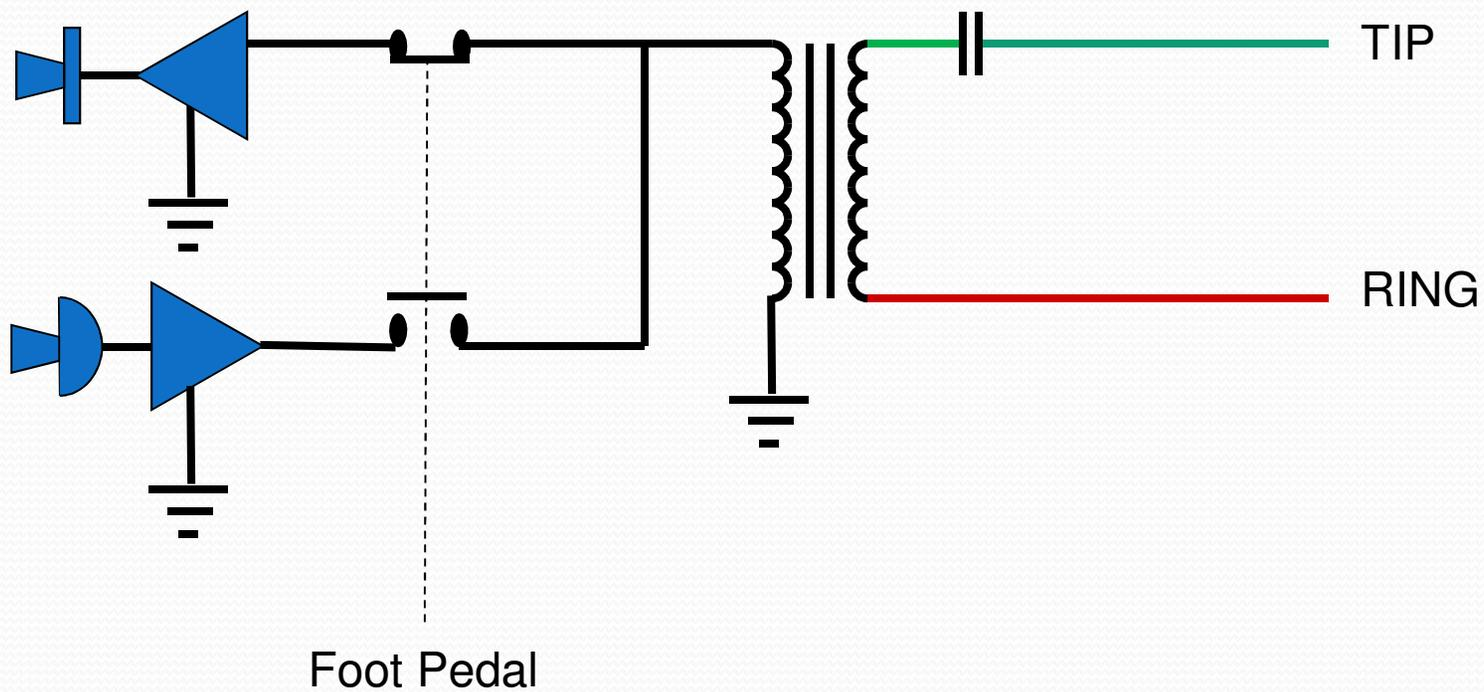

Large System Issues

- Have more stations (5 – 20)
- More phones off hook as crews tend to call in every time they see a red signal
- More phones means more ambient noise and less volume – combining loss
- Traditional phones don't work well with > 4 off hook – Communications Discipline!
- Systems with active combiners and amplification work better with large numbers of phones off hook
- Contact me if you are interested

Dispatcher Set Schematic

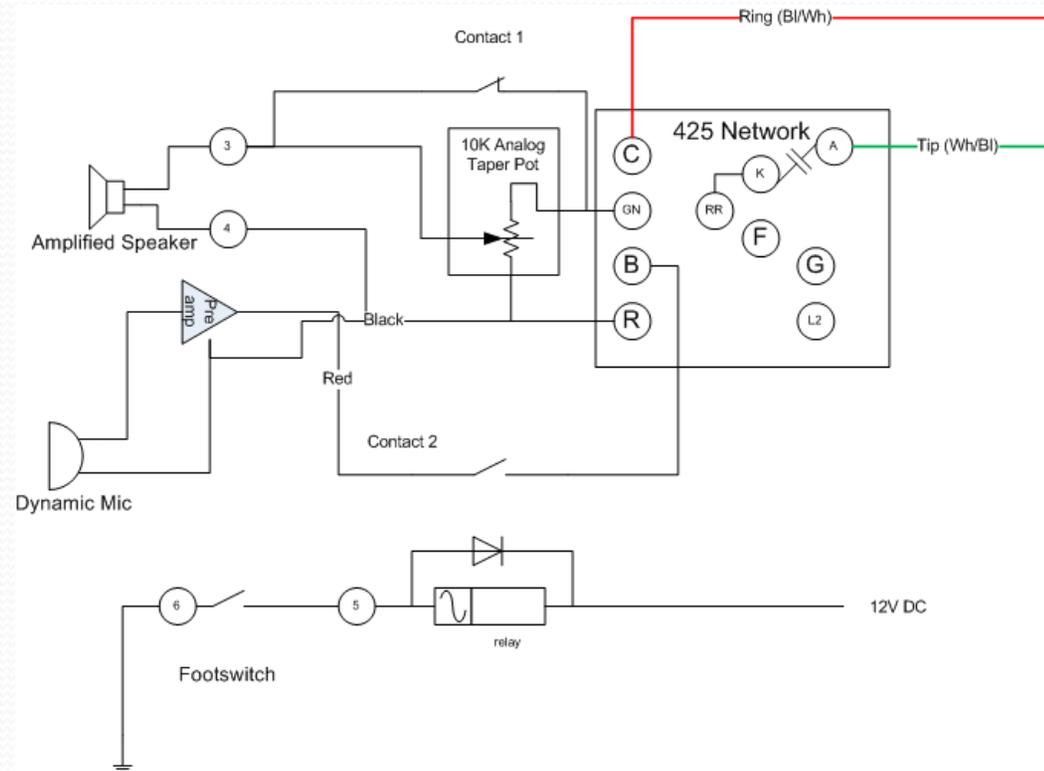

Dispatcher Bill of Materials

Quantity	Description	Price	Vendor
1	Microphone	\$ 20	RS, AMZN
1	Preamplifier - ART Tube MP	\$ 50	Sweetwater
1	Mic Stand	\$ 15	RS/Sweetwater
1	Speech Network	\$ 20	MRCS
1	Amplified Speaker	\$ 15 and up	RS, AMZN
1	Relay and socket	\$ 10	Jameco, RS
1	10K Audio Taper Pot	\$ 5	RS, Jameco
1	12V Regulated Wall Wart	\$ 15	RS, Jameco
1	Footswitch	\$ 20	MRCS
1	Misc Hardware	\$ 10	
	Total incl hardware	\$180	

Simple Phone System

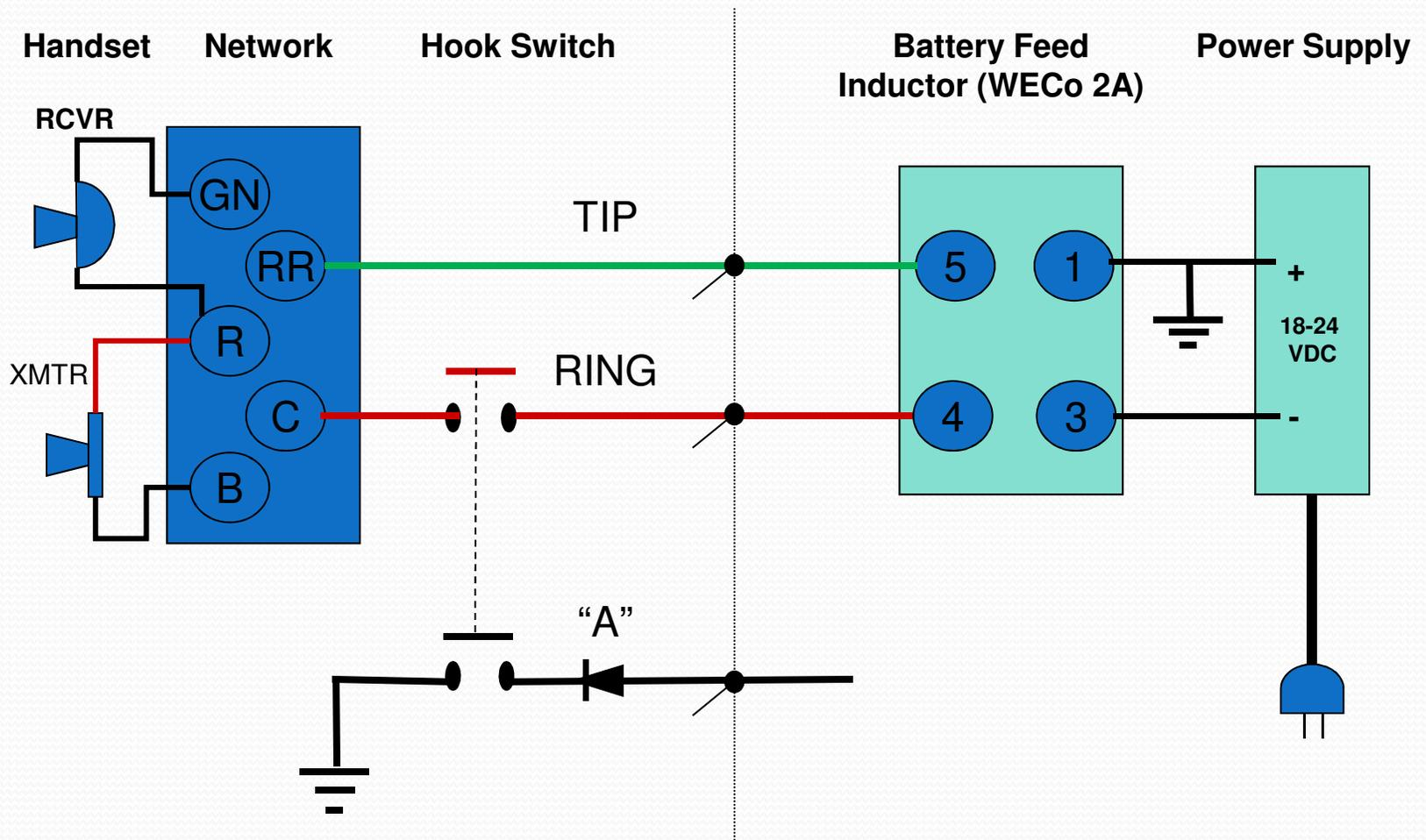

MRCs Dispatcher/Operator Board



Replacement of Commercial pre-Amp and discrete parts with a single board – saves on cables, power supplies, interconnects. Note dynamic mic, powered computer speakers

Same board, different application: Here we use a computer headset (good ones start at \$9.95) and a footswitch. Noise cancellation is pretty common on these headsets. This is great for an operator in an aisle!

